



# SURE GRIP BELT CLAMP

## MARK 1 OPERATING PROCEDURE

Patent No. US 6068318 • AU 740976

### MARK 1 MAXIMUM SCREW TENSION 50 N/M

#### ISOLATION

1. Ensure the conveyor belt is fully isolated and tagged out to the mines ISOLATION PROCEDURE.
2. Select position where clamp/clamps are to be used, clean belt of all forms of dirt, moisture and oils etc, unscrew both clamp bolts, remove end assemblies and separate the beams.
3. Position the bottom beam under the belt and support each end, **ensuring it is 90 degrees to the belt.**
4. Place the top beam into position, slide the end clamps over the top and bottom beam and ensure that clamps are placed against each edge of the conveyor belt.
5. If using a torque wrench ensure the correct pressure is applied to the tensioning bolts to ensure maximum clamping force. **(It is not necessary to over tighten main screw as 50 N/M applies a force of 1.5 tonnes).**
6. Connect the pulling appliances to the lugs of the clamps and tension until sufficient slack belt has been obtained. When two appliances are used, **operate them together and evenly.**
7. When clamps are butted up against stops or structure the supports should be no more than 30mm from each edge of the belt.
8. To remove the clamps when the belt repair is finished reverse the above procedure. Release all clamp bolts allowing tension in the belt to dissipate.
9. Remove the clamps and your danger tags once the belt is re-tensioned and ready to start.

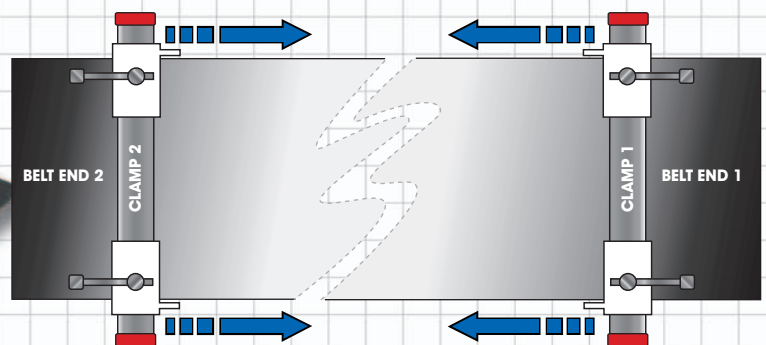
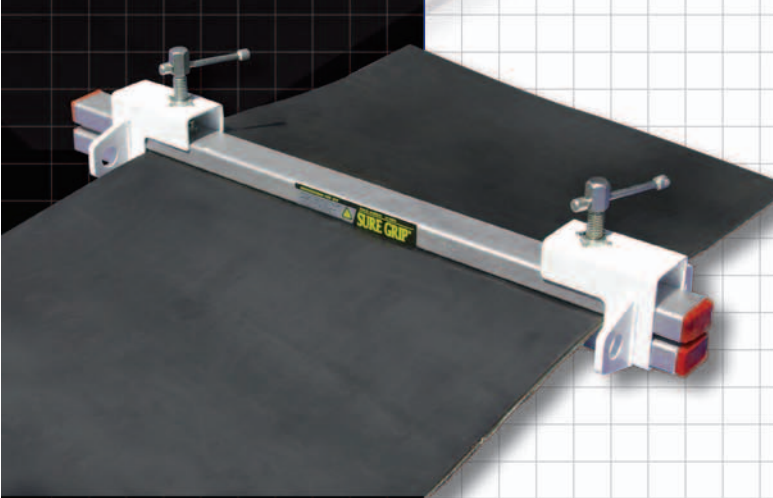

# MARK 1 OPERATING PROCEDURE

## SURE GRIP MARK 1 BELT CLAMP

### STORAGE

Clamps should be stored in the assembled position, to avoid damage and loss of items.

Torque 50 N/M = 50kg applied to the handle

Coefficient of friction = 0.14 on main screw

Force per clamp = 1.5 tonnes

Total clamp force on belt = 3 tonnes

Total force at belt creep = 3 tonnes = 3 – 1 safety factor  
= W.L.L.\* of 1 tonne

### BELT TYPE

600 k/n x 4 ply x 4 & 2 covers, N Grade Rubber

\* = Work Load Limit

